

REV	DESCRIPTION OF CHANGE	BY	DATE
A	BELT WIDTH 14 WAS 12, MTG HOLES 27.00 WAS 25.00	FCP	2/14/5

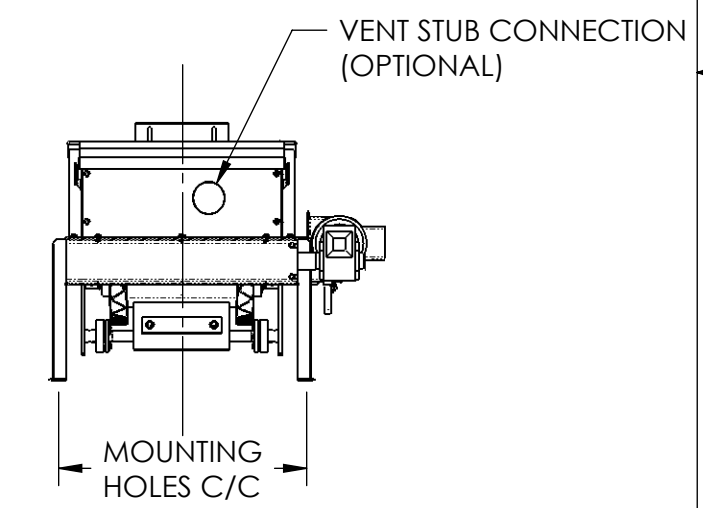
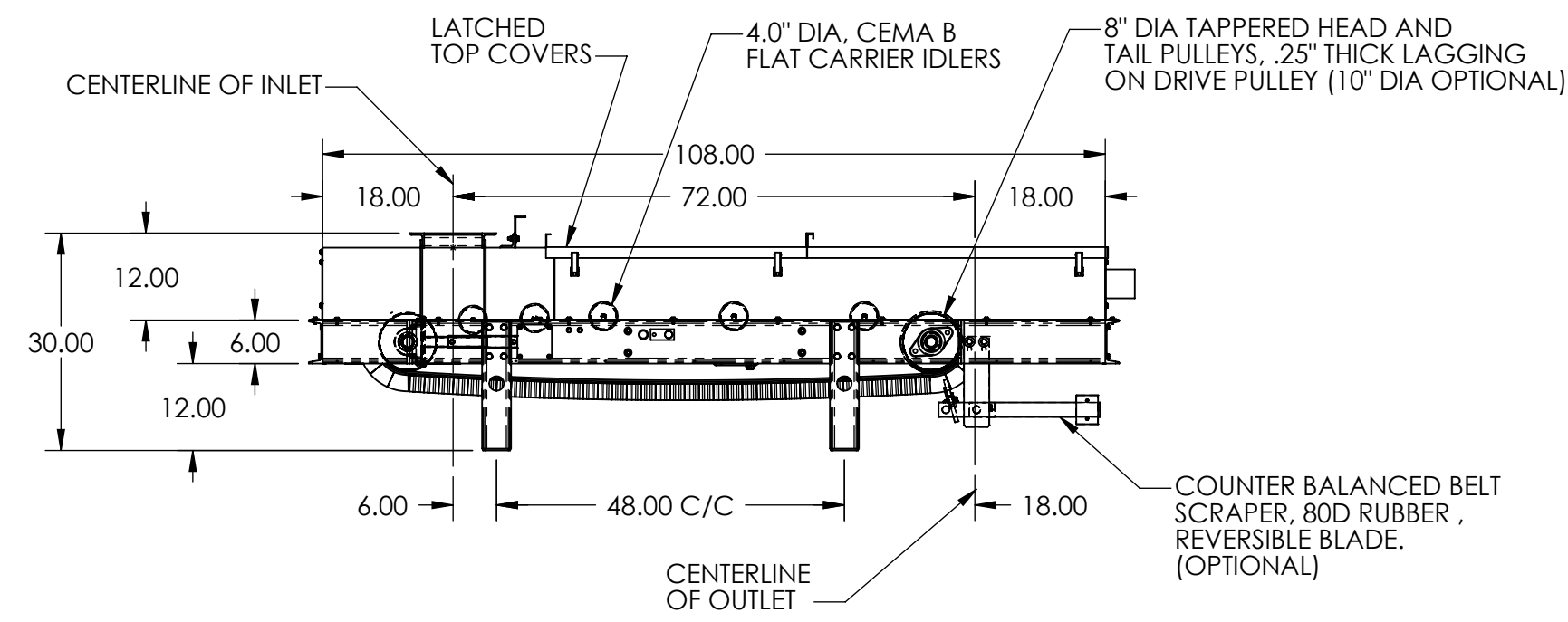
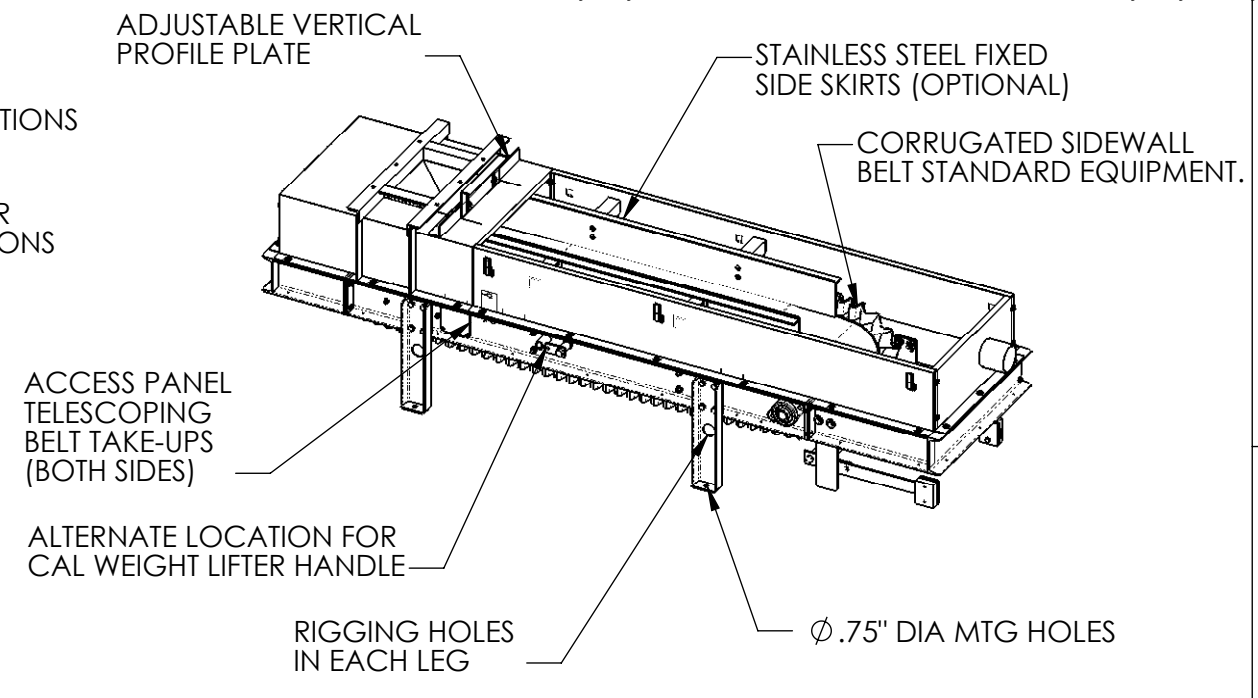
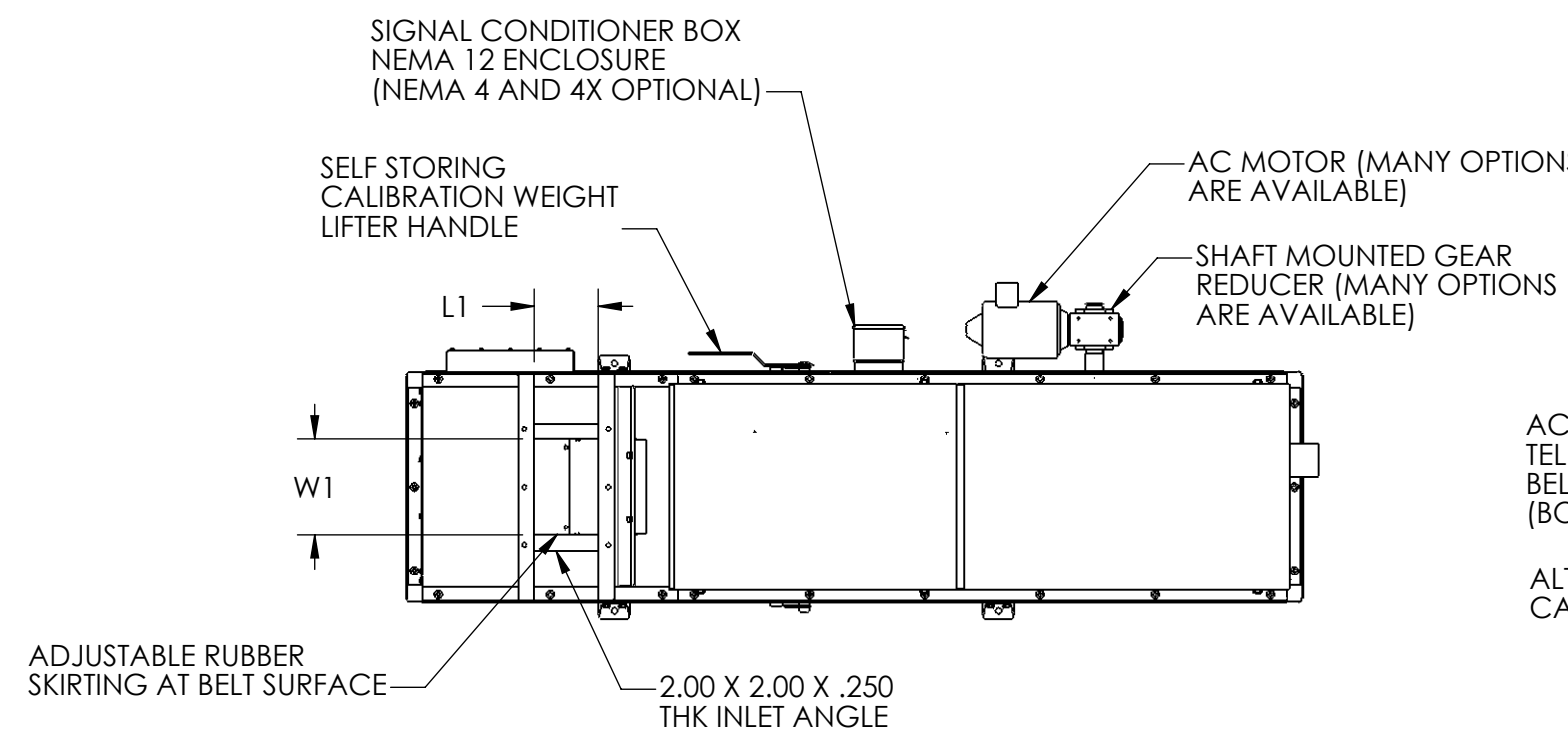

CONSTRUCTION NOTES:  
 FRAME: WELDED C6X8.2# AND C4X5.4# STRUCTURAL CHANNEL.  
 ENCLOSURE: WELDED AND MECHANICALLY FASTENED 10, 14 AND 16 GA CRS.  
 PAINT: TGIC-POLYESTER BAKED POWDER COAT, PEWTER COLOR

BELT WIDTH	MTG HOLES	INLET	
		W1	L1
14	27.00	8.00	8.00
18	31.00	12.00	8.00
24	37.00	18.00	8.00
30	43.00	24.00	10.00
36	49.00	30.00	10.00

UNLESS OTHERWISE SPECIFIED DIMENSIONS ARE IN INCHES, TOLERANCES ARE:

WELDMENTS		ASSEMBLIES	
DECIMALS	ANGLES	DECIMALS	ANGLES
.XX ± .06	± 1.0	.XX ± .12	± 1.0
.XXX ± .032		.XXX ± .063	

CAD GENERATED DRAWING, DO NOT MANUALLY UPDATE

1811 Buerkle Rd., St. Paul, MN 55110

TITLE: **OUTLINE DIMENSIONS**  
WF10-XX-6' TOP ENCLOSURE

APPROVALS: DRAWN: FCP, DATE: 7/27/4, CHECKED: , APPROVED:

DO NOT SCALE FROM DRAWING

THE INFORMATION CONTAINED IN THIS DRAWING IS THE SOLE PROPERTY OF TECWEIGH CORP. ANY REPRODUCTION IN PART OR WHOLE WITHOUT THE WRITTEN PERMISSION OF TECWEIGH CORPORATION IS PROHIBITED.

SIZE: DWG. NO. **26001048** REV. **A**  
SCALE: 1:24 SHEET 1 OF 1