



BULK BAG UNLOADER

CONTROL YOUR FLOW / IMPROVE YOUR PRODUCTIVITY

Tecweigh's® bulk bag unloader is engineered to make the handling of bulk bags easier, faster, safer and more cost effective. Tecweigh bulk bag unloaders are provided in a rugged welded steel frame with an oven-baked polyester powder coated finish that resists scratching, chipping and corrosion. For the utmost in performance and convenience, Tecweigh bulk bag unloaders can be easily integrated with a Tecweigh volumetric feeder.

Tecweigh bulk bag unloaders are available in two designs which provide an economical solution for the unloading of bulk bag materials. The fork lift design allows a fork lift to easily load a bulk bag onto the bag frame. The integral hoist beam design allows operators to handle the unloading of bulk bags without a forklift. The integral hoist design allows an operator to lift, support and position the bulk bag into position for fast and efficient material discharge.

Both styles of bulk bag unloaders are available with a unique adjustable agitator that gently massages the IBC bag to assure a constant regular flow, even with products that are difficult to handle.

Almost any size IBC bag fits a Tecweigh bulk bag unloader.

Each bulk bag frame is designed and built specifically for your application to ensure quick, efficient, ergonomically safe bulk bag unloading!



BBU

Weigh the Advantages Yourself

Count on Tecweigh Bulk Bag Unloaders to keep your process flowing



Shipping

Bulk bag frames are partially assembled for ease in field set-up. However, the framework can be "knocked down" to save on shipping and installation costs.

Call your local Tecweigh Representative or visit our web site for further information @ www.tecweigh.com

Features

- Heavy duty welded steel construction
- Easy to use fork truck bag support frame
- Adjustable height
- Baked on polyester powder coated finish

Options

- Agitator with adjustable width and speed
 - NEMA 4 control enclosure with digital speed control potentiometer
 - 1/2 or 3/4 HP DC motor
- Power hoist and trolley
- Air operated hoist and trolley
- Knock down framework that saves on shipping costs
- Volumetric Feeders
- Custom controls
- Custom applications
- Loss in Weight configurations

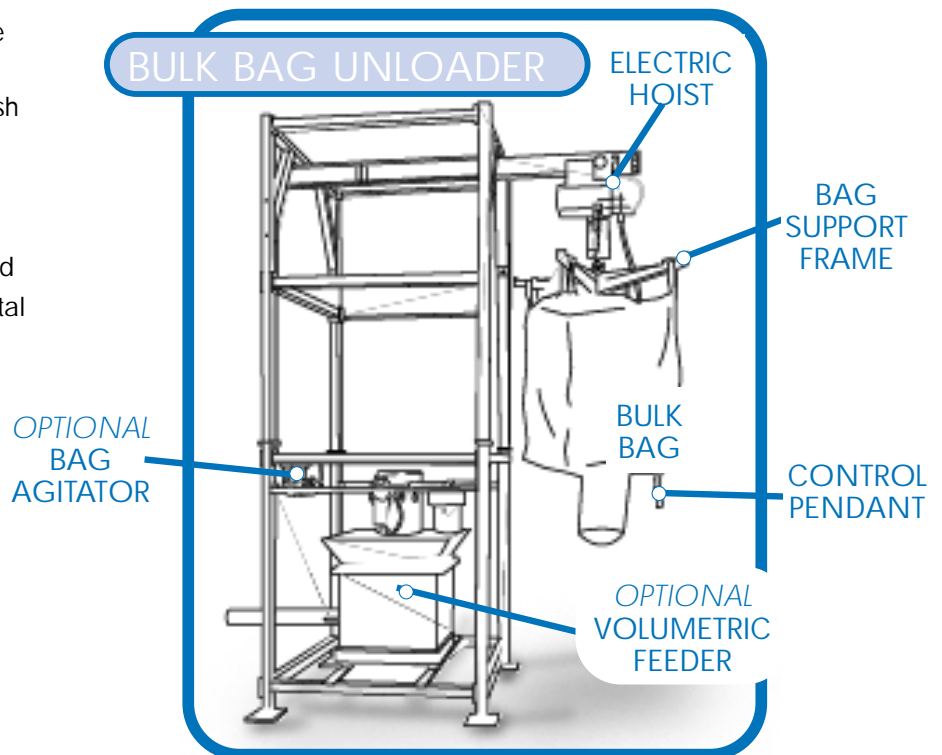

1811 Buerkle Road · Saint Paul, MN 55110
1-800-536-4880 · 651-777-4780 · FAX 651-777-5582

E-mail: sales@tecweigh.com

Web: www.tecweigh.com

In Australia contact:
Tecweigh Proprietary Ltd.
Phone +613 95480922
Web: www.tecweigh.com.au